

SPECIFICATION

OF

LIQUID CRYSTAL DISPLAY MODULE



CUSTOMER : URT-STD

Model No. : UMSH-8227MD-1T

Model version : 0

Document Revision : 1

CUSTOMER APPROVED SIGNATURE			

This specification need to be signed by purchaser or customer as a specification of products production and delivery from URT. Without signature of this specification , any purchase order for this model no. will be treated and considered that this specification is automatically acknowledged and accepted by purchaser or customer.

 **U.R.T.**  **UNITED RADIANT TECHNOLOGY CORPORATION**

Allen Wang
APPROVED

George Tseng
CHECKED

Angus Chiu
CHECKED

Sharon Tsai
PREPARED

Aug-13-2008
Date

COMPANY : No. 2,Fu-hsing Road,Taichung Economic Processing Zone,Tantzu,Taichung,Taiwan,R.O.C.

TEL: 886-4-25314277

FAX: 886-4-25313067



Revision 1 ; UMSH-8227MD-1T Ver. 0 ; August-13-2008

Page: 1

This document has been signed by Digital Signature Approval System

CONTENTS:

No.	Item	Page
1	BASIC SPECIFICATION 1.1 Mechanical Specification 1.2 Display Specification 1.3 Outline Dimension 1.4 Block Diagram 1.5 Interface Pin	4 4 5 6 7
2	ELECTRICAL CHARACTERISTICS 2.1 Absolute Maximum Ratings 2.2 DC Characteristics 2.3 Back-light 2.4 AC Characteristics	8 9 10 11~13
3	OPTICAL CHARACTERISTICS 3.1 Condition 3.2 Definition of Optical Characteristics	16 17~18
4	RELIABILITY	19
5	PRODUCT HANDING AND APPLICATION	20
6	DATECODE	21
7	PACKING & LOTNO	22~23
8	INSPECTION STANDARD	24~27

1. BASIC SPECIFICATION

1.1 Mechanical specifications

Items	Nominal Dimension	Unit
Active screen size	5.7" diagonal	-
Dot Matrix	640 x RGB x 480	dots
Module Size (W x H x T)	127.0 x 98.43 x 10.06	mm.
Active Area (W x H)	115.2 x 86.4	mm.
Dot Pitch (W x H)	0.18 x 0.18	mm.
Color depth	262K	color
Interface	Parallel 18-bit RGB	-
Driving IC Package	COG	-
Module weight	132	g

1.2 Display specification

Display	Descriptions	Note
LCD Type	a-Si TFT	
LCD Mode	TN / Normal white	
Polarizer Mode	Transmissive	
Polarizer Surface	Normal	
Pixel arrangement	RGB-stripe	
Backlight Type	LED	
Viewing Direction	6 O'clock Direction	

* Color tone is slightly changed by temperature and driving voltage.

1.3 Outline dimension

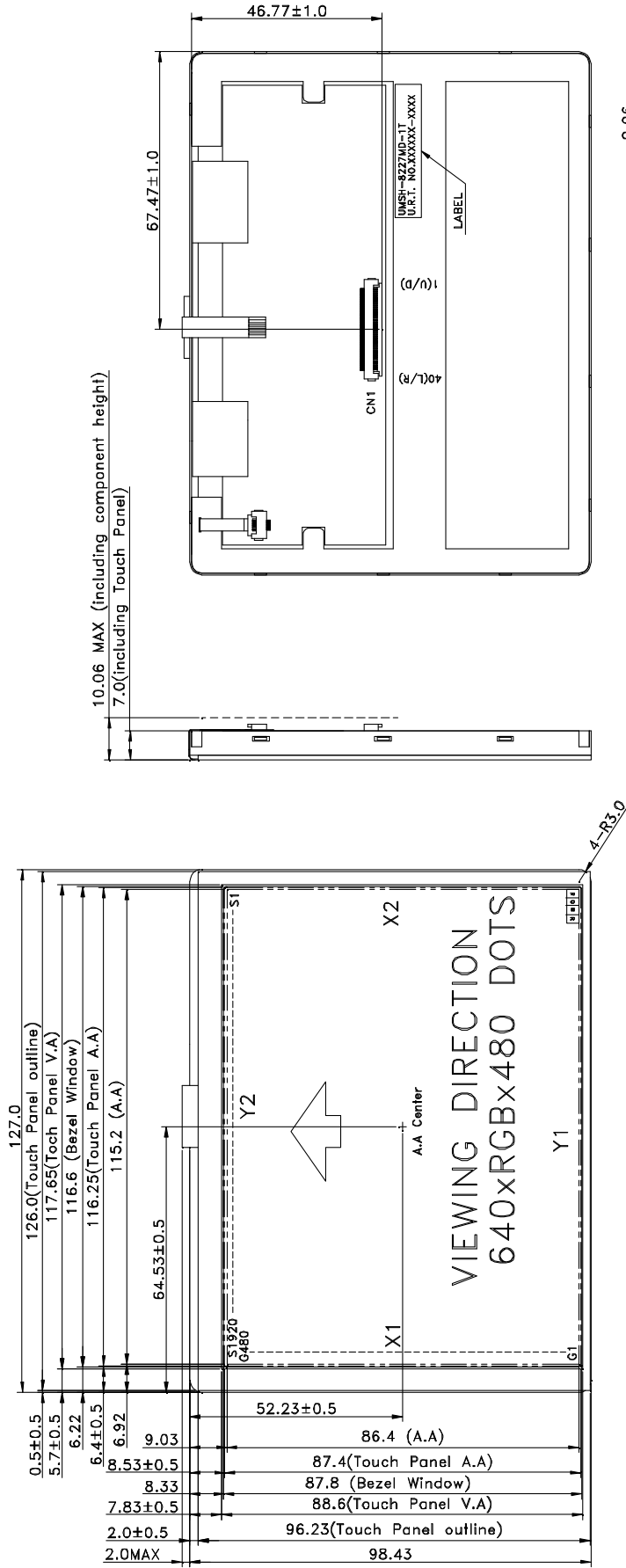

10.06 MAX (including component height)
7.0 (including Touch Panel)

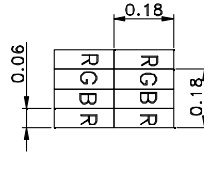
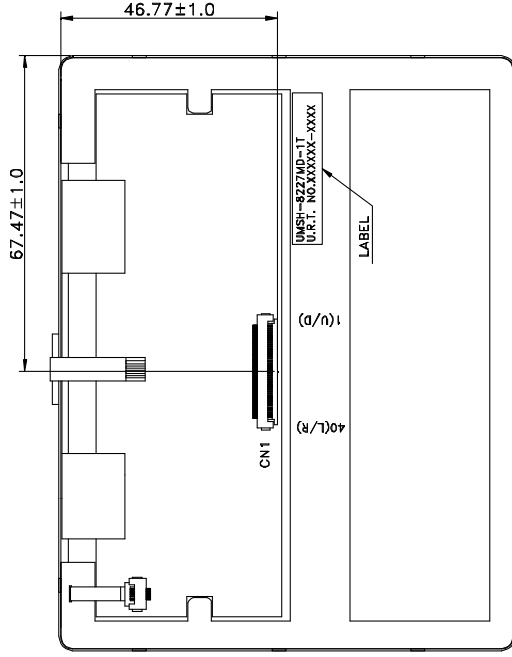

PIXEL SIZE

- NOTE :
1. LCD : TFT TRANSMISSIVE TYPE , NORMAL WHITE
 2. VIEWING DIRECTION : 6 O'CLOCK
 3. Top : -20~70°C , Tst : -30~80°C
 4. LED BACKLIGHT COLOR : WHITE
 5. CONSTANT VOLTAGE FOR LED DRIVER : VLED=5.0 V, ILED=340.0mA(TYP.)
 6. BRIGHTNESS : 175 cd/m² (MIN), 250 cd/m² (TYP)
 7. TOLERANCE FOR NOT ASSIGNED : ±0.3mm
 8. RoHS-COMPLIANT
 9. CN1 : 6705-E40N-00R(E&T)
 10. CUSTOMER BEZEL WINDOW MUST BE SMALLER THAN TOUCH PANEL
A.A.(116.25 mm X 87.4 mm)
 11. CUSTOMER CUSHION WINDOW MUST BE LARGER THAN TOUCH PANEL
V.A.(117.65 mm X 88.6 mm)0.5 mm
 12. "△" URT REQUEST PROPERTY

1.4 Block diagram:

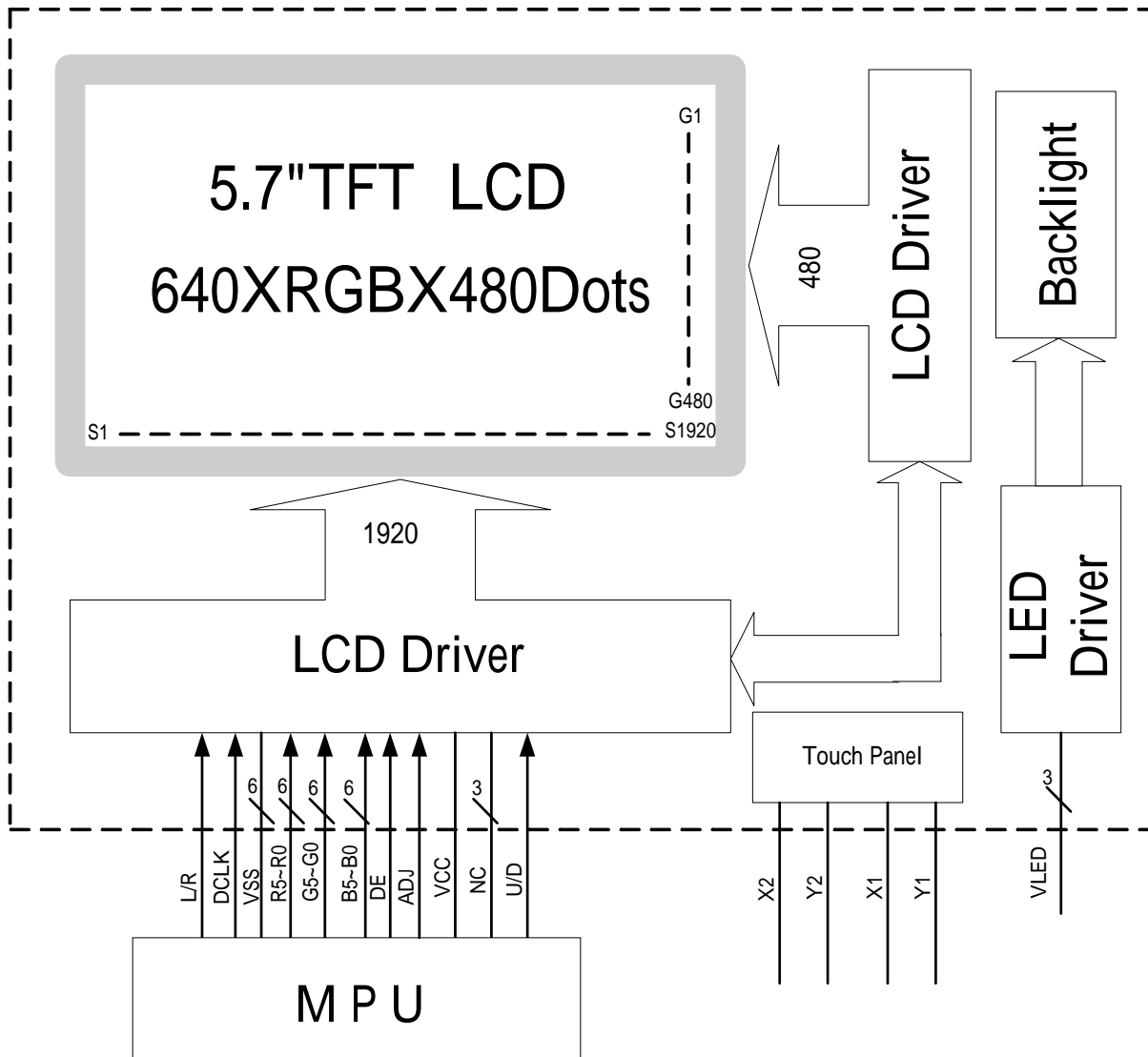

1.5 Interface pin :

Pin No.	Pin Symbol	I/O	Description
1	U/D	I	Up or Down Display Control
2~3	NC	-	Customer non-connect.
4~6	VLED	P	Power supply for digital circuit LED.(+5.0V)
7	VCC	P	Power supply for digital circuit LCD. (+3.3V)
8	NC	-	Customer non-connect.
9	DE	I	Data enable
10	X2	-	Touch Screen
11	Y1	-	Touch Screen
12	ADJ	I	Adjust for LED brightness.(PWM)
13	B5	I	Blue data input (MSB)
14、15	B4、B3	I	Blue data input
16	VSS	P	Power ground
17、18	B2、B1	I	Blue data input
19	B0	I	Blue data input (LSB)
20	VSS	P	Power ground
21	G5	I	Green data input (MSB)
22、23	G4、G3	I	Green data input
24	VSS	P	Power ground
25、26	G2、G1	I	Green data input
27	G0	I	Green data input (LSB)
28	VSS	P	Power ground

Pin No.	Pin Symbol	I/O	Description
29	R5	I	Red data input (MSB)
30、31	R4、R3	I	Red data input
32	VSS	P	Power ground
33、34	R2、R1	I	Red data input
35	R0	I	Red data input (LSB)
36	X1	-	Touch Screen
37	Y2	-	Touch Screen
38	DCLK	I	Clock signals.
39	VSS	P	Power ground
40	L/R	I	Left or Right Display Control

2. ELECTRICAL CHARACTERISTICS

2.1 Absolute Maximum Ratings

Items	Symbol	Min.	Max.	Unit
Power supply voltage	VCC	-0.3	7.0	V
Input voltage	V _{in}	-0.3	VCC+0.3	V
Operate temperature range	T _{OP}	-20	70	°C
Storage temperature range	T _{ST}	-30	80	°C

2.2 DC Characteristics

$T_a = 25^\circ\text{C}$

Items	Symbol	Min.	Typ.	Max.	Unit	Condition
Supply voltage	V_{CC}	-	3.3	-	V	-
Input Voltage	V_{IL}	0	-	$0.3V_{CC}$	V	L level
	V_{IH}	$0.7V_{CC}$	-	V_{CC}	V	H level
Current consumption	I_{CC}	-	-	135	mA	Note 1

*Note1 :

Measuring Condition:

Standard Value MAX.

$T_a = 25^\circ\text{C}$

$V_{CC} - GND = 3.3\text{V}$

Display Pattern = Check pattern



0 gray black pattern

2-2.1 Back-light Characteristics

PARAMETER	SYMBOL	MIN	TYP	MAX	Unit	Test Condition	NOTE
Supply Current	I_f	-	340	680	mA	$T_a = 25^\circ\text{C}$	-
Supply Voltage	V_f	-	5	-	V	$T_a = 25^\circ\text{C}$	-
Half-Life Time	L_f	-	50000	-	hrs	$T_a = 25^\circ\text{C}$	1

Note 1 : The “ Half-Life Time ” is defined as the module brightness decrease to 50% original brightness.

2.3 AC Characteristics

Digital Parallel RGB interface (1920x480 resolution)

PARAMETER	Symbol	Spec.			Unit
		Min.	Typ.	Max.	
CLK frequency	F_{CPH}	-	25.175	-	MHz
CLK period	T_{CPH}	-	39.7	-	ns
CLK pulse duty	T_{CWH}	40	50	60	%
HS period	T_H	-	800	-	T_{CPH}
HS pulse width	T_{WH}	5	30	-	T_{CPH}
HS-first horizontal data time	T_{HS}	112	144	175	T_{CPH}
DEN pulse width	T_{EP}	-	640	-	T_{CPH}
VS pulse width	T_{WV}	1	3	5	T_H
VS-DEN time	T_{STV}	-	35	-	T_H
VS period	T_V	-	525	-	T_H

Note: When SYNC mode is used, 1st data start from 144th CLK after HS falling (when $STHD[5:0]=00000$)

PARAMETER	Symbol	Spec.			Unit
		Min.	Typ.	Max.	
OEV pulse width	T_{OEV}	-	100	-	T_{CPH}
CKV pulse width	T_{CKV}	-	96	-	T_{CPH}
HS-CKV time	T_1	-	52	-	T_{CPH}
HS-OEV time	T_2	-	8	-	T_{CPH}
HS-POL time	T_3	-	72	-	T_{CPH}
STV setup time	T_{SUV}	-	46	-	T_{CPH}
STV pulse width	T_{WSTV}	-	1	-	T_H

2.4 Interface Timing Chart

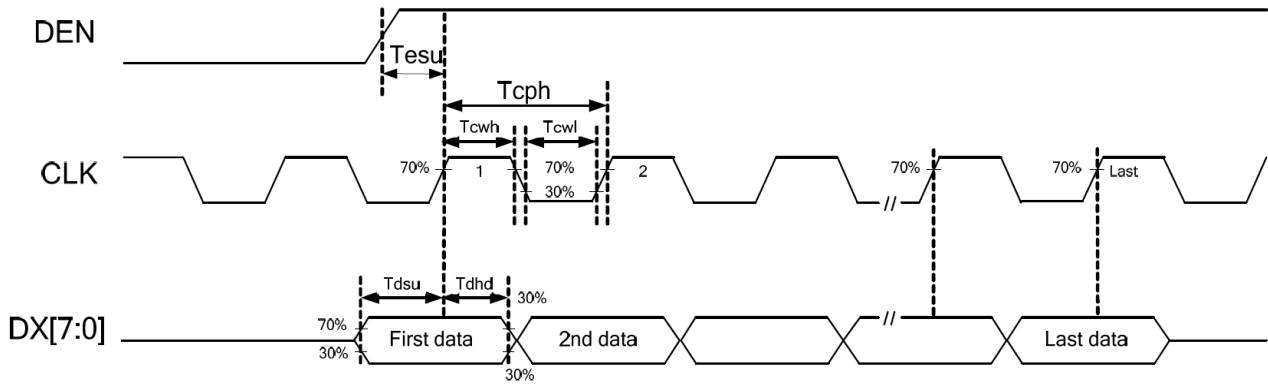

2.4.1 Data input format for RGB Mode

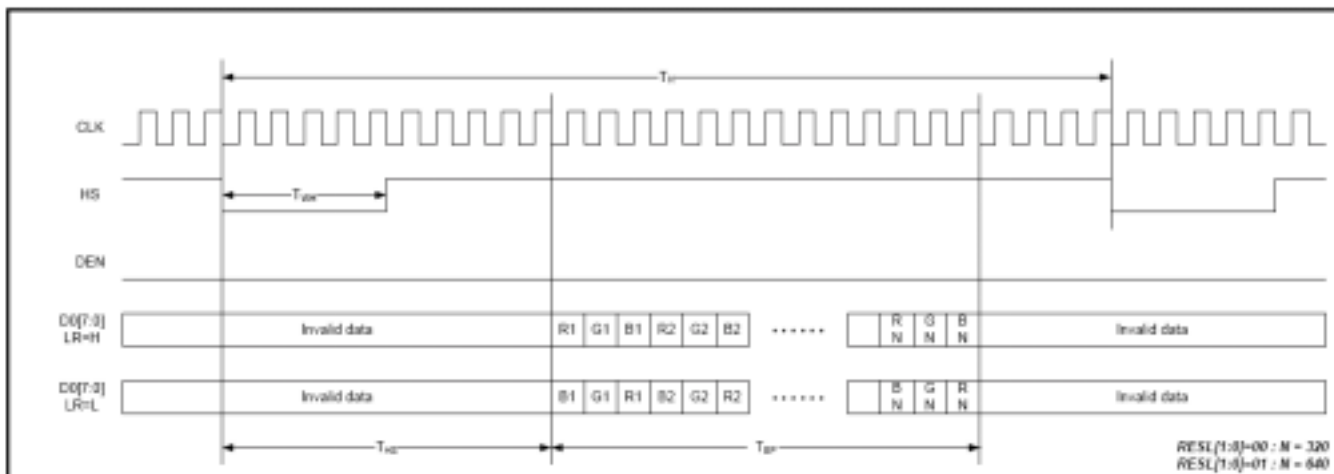

3. OPTICAL CHARACTERISTICS

3.1 Characteristics

Electrical and Optical Characteristics

No.	Item	symbol / temp.	Min.	Typ.	Max.	Unit	Note		
1	Response Time	Tr	25	-	15	-	ms	2	
		Tf	25	-	35	-			
2	Viewing Angle	Hor.	x+	Center CR>=10	-	60	-	degree	3
			x-		-	60	-		
		Ver.	y+		-	45	-		
			y-		-	60	-		
3	Contrast Ratio	Cr	25	250	350	-	-	4	
4	Red x-code	Rx	25	0.57	0.62	0.67	-	5	
	Red y-code	Ry		0.31	0.36	0.41			
	Green x-code	Gx		0.29	0.34	0.39			
	Green y-code	Gy		0.53	0.58	0.63			
	Blue x-code	Bx		0.09	0.14	0.19			
	Blue y-code	By		0.09	0.14	0.19			
	White x-code	Wx		0.29	0.34	0.39			
	White y-code	Wy		0.33	0.38	0.43			
	Brightness	Y		175	250	-			cd/m ²
5	Brightness Uniformity		25	80	-	-	%	6	

3.2 Definition of optical characteristics

Measurement condition :

Transmissive and Transflective type

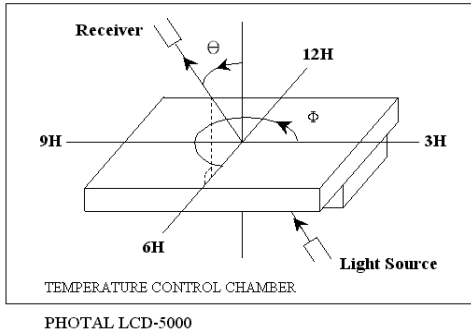

[Note 1] Definition of LCD Driving Vop and Waveform :

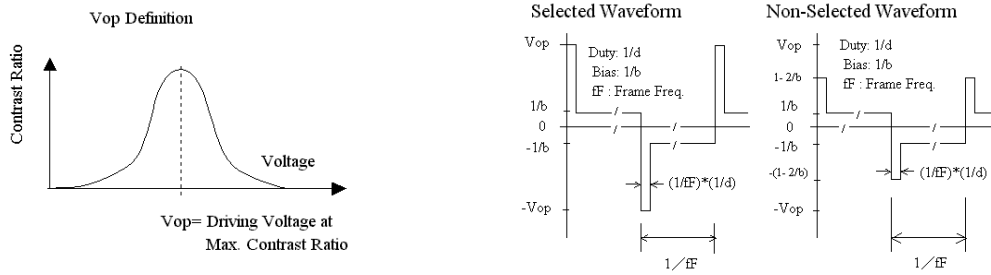

[Note 2] Definition of Response Time

for Positive type :

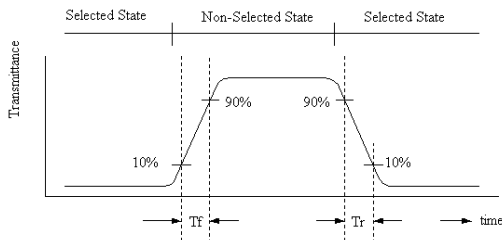

[Note 3] Definition of Viewing Angle :

[Note 4] Definition of Contrast Ratio :

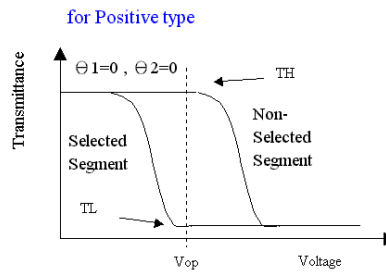
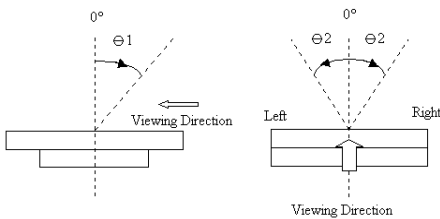

$$\text{Contrast Ratio} = \frac{TH}{TL}$$

[Note 5] Definition of measurement of Color Chromaticity and Brightness

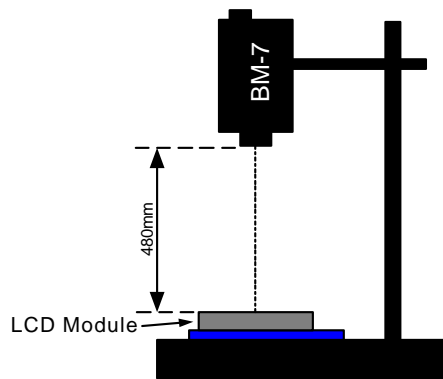

[Note 6] Definition of Brightness Uniformity

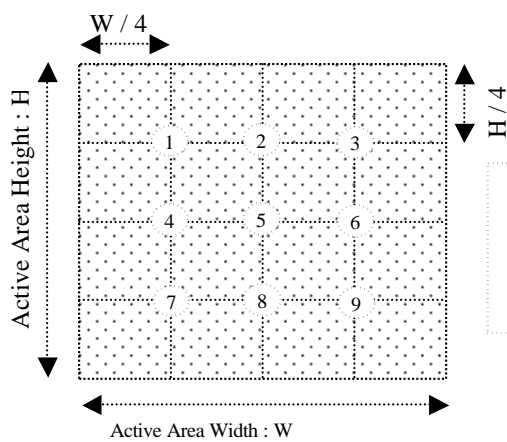

$$\text{Brightness Uniformity} = \frac{\text{Minimum Brightness of Point 1~9}}{\text{Maximum Brightness of Point 1~9}}$$

[Note 7] Definition of Measurement of Reflectance

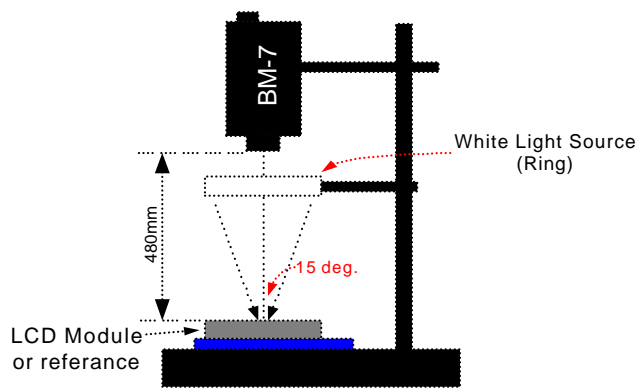

4. RELIABILITY :

Item No	Items	Condition
1	High temperature operating	70 , 200 hours
2	Low temperature operating	-20 , 200 hours
3	High temperature storage	80 , 200 hours
4	Low temperature storage	-30 , 200 hours
5	High temperature & humidity storage	60 , 90%RH, 100 hours
6	Thermal Shock storage	-30 , 30min.<=> 80 , 30min. 10 Cycles
7	Vibration test	10 => 55 =>10 => 55 => 10 Hz , within 1 minute Amplitude : 1.5mm. 15 minutes for each Direction (X,Y,Z)
8	Drop test	Packed, 100CM free fall, 6 sides, 1 corner, 3edges
9	Life time	50,000 hours 25 , 70%RH below , specification condition driving

* One single product test for only one item.

* Judgment after test : keep in room temperature for more than 2 hours.

- Current consumption < 2 times of initial value
- Contrast > 1/2 initial value
- Function : work normally

5. PRODUCT HANDLING AND APPLICATION

PRECAUTION FOR HANDLING LCM

The LCD module contains a C-MOS LSI. People who operate the LCM should wear ESD protection equipment to prevent ESD hurt on products.

Do not input any signal before power is turned on.

Do not take LCM from its packaging bag until it is assembled.

Peel off the LCM protective film slowly since static electricity may be generated.

Pay attention to the humidity of the work shop, 50~60%RH is satisfactory.

Use a non-leak iron for soldering LCM.

Do not touch the display surface or connection terminals area with bare hands. Smudges on the display surface reduce the insulation between terminals.

Cautions for soldering to LCM:

Condition for soldering I/O terminals:

Temperature at iron tip :280 ±10 .

Soldering time : 3~4sec./ terminals.

Type of solder : Eutectic solder(rosin flux filled).

PRECAUTION IN USE OF LCD

Do not contact or scratch the front surface and the contact pads of a LCD panel with hard materials such as metal or glass or with one's nail.

To clean the surface , wipe it gently with soft cloth dampened by alcohol.

Do not attempt to wipe off the contact pads.

Keep LCD panels away from direct sunlight , also avoid them in high-temperature & high humidity environment for a long period.

Do not drive LCD panels by DC voltage.

Do not expose LCD panels to organic solvent.

Liquid in LCD is hazardous substance. In case a contact with liquid crystal material is occurred, be sure to immediately wash such material away by soap and water.

The polarizer is easily damaged and should be handle with special care. Don't press or rub it with hard objects.

PRECAUTION FOR STORING LCM

To avoid degradation of the device , do not store the module under the conditions of direct sunlight , high temperature or high humidity . Keep the module in bags designed to prevent static electricity charging under low temperature / normal humidity conditions(avoid high temperature / high humidity and low temperature below 0)

USING ON MEDICAL CARE , SAFETY OR HAZARDOUS APPLICATION OR SYSTEM

For the application in medical care, safety and hazardous products or systems, an authorization from URT is required. URT will not responsible for any damage or loss which caused by the products without any authorization given by URT.

This product is not allowed to be designed and used for military application and/or purpose.

The delivery of this product to the countries and/or regions where the embargoes are imposed by U.N. is prohibited.

6. DATE CODE OF PRODUCTS

Date code will be shown on each product :

Y MM DD - XXX
| | | |
Year Month Day - Production lots

Example: 2 1 2 2 3 - 0 0 3 ==>Year 2002, Dec.,23rd , Batch no.03

MODEL NO: UM*

T.B.D pcs / Tray

T.B.D Tray / Box

T.B.D Box / Carton

T.B.D pcs / Carton

NOTE:

(1) Be warned, the direction of the tray has to turn it by 180 degree before stack it up. Otherwise, it will be packager's responsibility!!

(2) Safe Stack : 5 cartons only

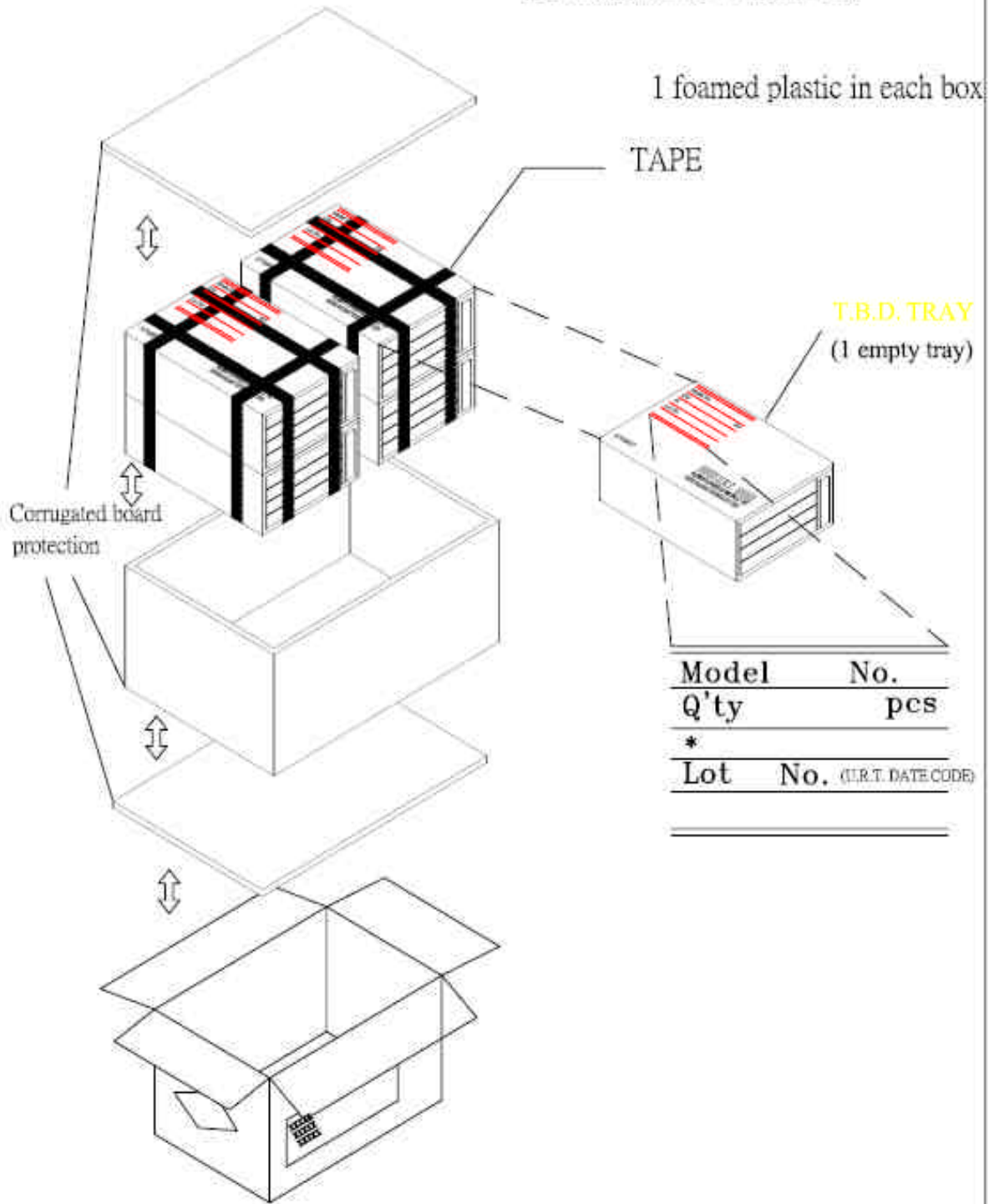

8. INSPECTION STANDARD

8.1. QUALITY :

THE QUALITY OF GOODS SUPPLIED TO PURCHASER SHALL COME UP TO THE FOLLOWING STANDARD.

8.1.1. THE METHOD OF PRESERVING GOODS

AFTER DELIVERY OF GOODS FROM U.R.T. TO PURCHASER. PURCHASER SHALL CONTROL THE LCM AT -10 40 ,AND IT MIGHT BE DESIRABLE TO KEEP AT THE NORMAL ROOM TEMPERATURE AND HUMIDITY UNTIL INCOMING INSPECTION OR THROWING INTO PROCESS LINE.

8.1.2. INCOMING INSPECTION

(A) THE METHOD OF INSPECTION

IF PURCHASER MAKE AN INCOMING INSPECTION , A SAMPLING PLAN SHALL BE APPLIED ON THE CONDITION THAT QUALITY OF ONE DELIVERY SHALL BE REGARDED AS ONE LOT.

(B) THE STANDARD OF QUALITY

ISO-2859-1 (or MIL-STD-105E) , LEVEL SINGLE PLAN.

CLASS	AQL(%)
CRITICAL	0.4 %
MAJOR	0.65 %
MINOR	1.5 %
TOTAL	1.5 %

EVERY ITEM SHALL BE INSPECTED ACCORDING TO THE CLASS.

(C) MEASURE

IF AS THE RESULT OF ABOVE RECEIVING INSPECTION , A LOT OUT IS DISCOVERED. PURCHASER SHALL BE INFORM SELLER OF IT WITHIN SEVEN DAYS. BUT FIRST SHIPMENT WITHIN FOURTEEN DAYS.

8.1.3. WARRANTY POLICY

U.R.T. WILL PROVIDE ONE-YEAR WARRANTY FOR THE PRODUCTS ONLY IF UNDER SPECIFICATION OPERATING CONDITIONS. U.R.T. WILL REPLACE NEW PRODUCTS FOR THESE DEFECT PRODUCTS WHICH UNDER WARRANTY PERIOD AND BELONG TO THE RESPONSIBILITY OF U.R.T.

8.2. CHECKING CONDITION

8.2.1. CHECKING DIRECTION SHALL BE IN THE 45 DEGREE AREA TO FACE THE SAMPLE.

8.2.2. CHECKER SHALL SEE OVER 30 cm. WITH BARE EYES FAR FROM SAMPLE AND USING 2 PCS. OF 20W FLUORESCENT LAMP.

8.3. INSPECTION PLAN :

CLASS	ITEM	JUDGEMENT	CLASS
PACKING & INDICATE	1. OUTSIDE AND INSIDE PACKAGE	"MODEL NO." , "LOT NO." AND "QUANTITY" SHOULD INDICATE ON THE PACKAGE.	Minor
	2. MODEL MIXED AND QUANTITY	OTHER MODEL MIXED.....REJECTED QUANTITY SHORT OR OVER.....REJECTED	Critical
	3. PRODUCT INDICATION	"MODEL NO." SHOULD INDICATE ON THE PRODUCT	Major
ASSEMBLY	4. DIMENSION, LCD GLASS SCRATCH AND SCRIBE DEFECT.	ACCORDING TO SPECIFICATION OR DRAWING.	Major
APPEARANCE	5. VIEWING AREA	POLARIZER EDGE OR LCD'S SEALING LINE IS VISABLE IN THE VIEWING AREAREJECTED	Minor
	6. BLEMISH, BLACK SPOT, WHITE SPOT IN THE LCD AND LCD GLASS CRACKS	ACCORDING TO STANDARD OF VISUAL INSPECTION (INSIDE VIEWING AREA)	Minor
	7. BLEMISH, BLACK SPOT WHITE SPOT AND SCRATCH ON THE POLARIZER	ACCORDING TO STANDARD OF VISUAL INSPECTION (INSIDE VIEWING AREA)	Minor
	8. BUBBLE IN POLARIZER	ACCORDING TO STANDARD OF VISUAL INSPECTION (INSIDE VIEWING AREA)	Minor
	9. LCD'S RAINBOW COLOR	STRONG DEVIATION COLOR (OR NEWTON RING) OF LCD.....REJECTED. OR ACCORDING TO LIMITED SAMPLE (IF NEEDED, AND INSIDE VIEWING AREA)	Minor
ELECTRICAL	10. ELECTRICAL AND OPTICAL CHARACTERISTICS (CONTRAST, VOP, CHROMATICITY ... ETC)	ACCORDING TO SPECIFICATION OR DRAWING . (INSIDE VIEWING AREA)	Critical
	11.MISSING LINE	MISSING DOT, LINE, CHARACTERREJECTED	Critical
	12.SHORT CIRCUIT, WRONG PATTERN DISPLAY	NON DISPLAY, WRONG PATTERN DISPLAY, CURRENT CONSUMPTION OUT OF SPECIFICATION..... REJECTED	Critical
	13. PIN HOLE, PATTERN DEFORMITY	ACCORDING TO STANDARD OF VISUAL INSPECTION	Minor

8.4. STANDARD OF VISUAL INSPECTION

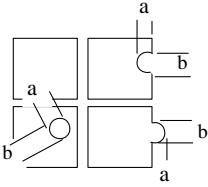
NO.	CLASS	ITEM	JUDGEMENT																																			
8.4.1	MINOR	<p>. BLEMISH, BLACK SPOT, WHITE SPOT IN THE LCD.</p> <p>. BLEMISH, BLACK SPOT, WHITE SPOT AND SCRATCH ON THE POLARIZER</p>	<p>(A) ROUND TYPE: unit : mm.</p> <table border="1"> <thead> <tr> <th colspan="2">DIAMETER (mm.)</th> <th>ACCEPTABLE Q'TY</th> </tr> </thead> <tbody> <tr> <td colspan="2">0.1</td> <td>DISREGARD</td> </tr> <tr> <td>0.1 <</td> <td>0.2</td> <td>2</td> </tr> <tr> <td>0.2 <</td> <td>0.25</td> <td>1</td> </tr> <tr> <td>0.25 <</td> <td></td> <td>0</td> </tr> </tbody> </table> <p>NOTE: $=(\text{LENGTH}+\text{WIDTH})/2$</p> <p>(B) LINER TYPE: unit : mm.</p> <table border="1"> <thead> <tr> <th>LENGTH</th> <th colspan="2">WIDTH</th> <th>ACCEPTABLE Q'TY</th> </tr> </thead> <tbody> <tr> <td>-----</td> <td>W</td> <td>0.03</td> <td>DISREGARD</td> </tr> <tr> <td>L 5.0</td> <td>0.03 <</td> <td>W 0.05</td> <td>3</td> </tr> <tr> <td>L 5.0</td> <td>0.05 <</td> <td>W 0.07</td> <td>1</td> </tr> <tr> <td>-----</td> <td>0.07 <</td> <td>W</td> <td>FOLLOW ROUND TYPE</td> </tr> </tbody> </table>	DIAMETER (mm.)		ACCEPTABLE Q'TY	0.1		DISREGARD	0.1 <	0.2	2	0.2 <	0.25	1	0.25 <		0	LENGTH	WIDTH		ACCEPTABLE Q'TY	-----	W	0.03	DISREGARD	L 5.0	0.03 <	W 0.05	3	L 5.0	0.05 <	W 0.07	1	-----	0.07 <	W	FOLLOW ROUND TYPE
DIAMETER (mm.)		ACCEPTABLE Q'TY																																				
0.1		DISREGARD																																				
0.1 <	0.2	2																																				
0.2 <	0.25	1																																				
0.25 <		0																																				
LENGTH	WIDTH		ACCEPTABLE Q'TY																																			
-----	W	0.03	DISREGARD																																			
L 5.0	0.03 <	W 0.05	3																																			
L 5.0	0.05 <	W 0.07	1																																			
-----	0.07 <	W	FOLLOW ROUND TYPE																																			
8.4.2	MINOR	BUBBLE IN POLARIZER	<p style="text-align: right;">unit : mm.</p> <table border="1"> <thead> <tr> <th>DIAMETER</th> <th>ACCEPTABLE Q'TY</th> </tr> </thead> <tbody> <tr> <td>0.15</td> <td>DISREGARD</td> </tr> <tr> <td>0.15 <</td> <td>2</td> </tr> <tr> <td>0.5 <</td> <td>0</td> </tr> </tbody> </table>	DIAMETER	ACCEPTABLE Q'TY	0.15	DISREGARD	0.15 <	2	0.5 <	0																											
DIAMETER	ACCEPTABLE Q'TY																																					
0.15	DISREGARD																																					
0.15 <	2																																					
0.5 <	0																																					
8.4.3	MINOR	PIN HOLE , PATTERN DEFORMITY	<p style="text-align: right;">unit : mm.</p>  <table border="1"> <thead> <tr> <th>DIAMETER</th> <th>ACC. Q'TY</th> </tr> </thead> <tbody> <tr> <td>0.1</td> <td>DISREGARD</td> </tr> <tr> <td>0.1 <</td> <td>0.25</td> <td>3</td> </tr> <tr> <td>0.25 <</td> <td></td> <td>0</td> </tr> </tbody> </table> <p>$= (a+b)/2$</p>	DIAMETER	ACC. Q'TY	0.1	DISREGARD	0.1 <	0.25	3	0.25 <		0																									
DIAMETER	ACC. Q'TY																																					
0.1	DISREGARD																																					
0.1 <	0.25	3																																				
0.25 <		0																																				

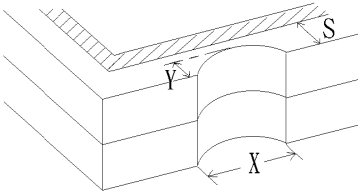
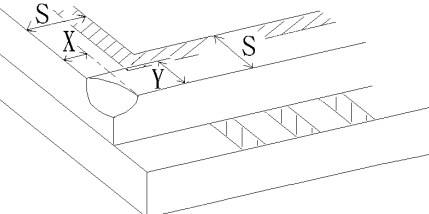
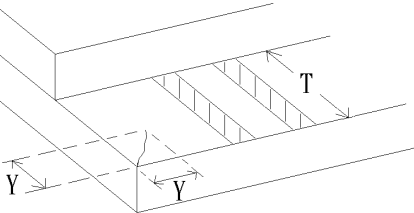
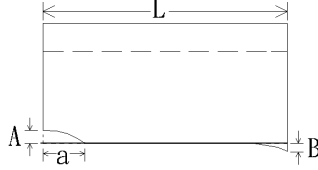
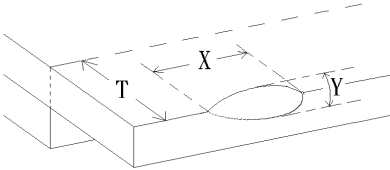
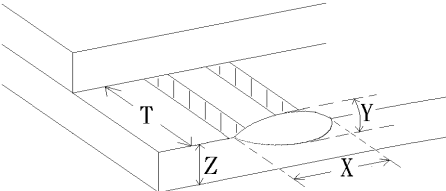
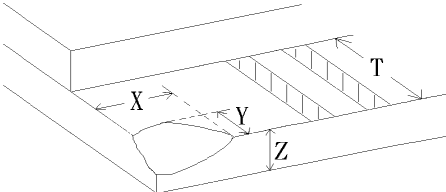
NO.	CLASS	ITEM	JUDGEMENT
8.4.4	MINOR	CHIPPING	 $Y > S$ REJ.
8.4.5	MINOR	CHIPPING	 $X \text{ or } Y > S$ REJ.
8.4.6	MAJOR	GLASS CRACK	 $Y > (1/2) T$ REJ.
8.4.7	MAJOR	SCRIBE DEFECT	 <ol style="list-style-type: none"> $a > L/3$, $A > 1.5\text{mm}$. REJ. B: ACCORDING TO DIMENSION
8.4.8	MINOR	CHIPPING (ON THE TERMINAL AREA)	 $= (x+y)/2 > 2.5 \text{ mm}$ REJ.
8.4.9	MINOR	CHIPPING (ON THE TERMINAL SURFACE)	 $Y > (1/3) T$ REJ.
8.4.10	MINOR	CHIPPING	 $Y > T$ REJ.